

**Odometer Gears Ltd.**

**757-593-3478**

**www.odometergears.com**

# **Parking Brake Fix**

BMW E65/66 2002 - 08

Rolls Royce Phantom 2003 - present

© copywrite 2011

Also see video instructions: [http://www.odometergears.com/how\\_to.php](http://www.odometergears.com/how_to.php)

The parking brake actuator (#1) is located in the trunk in front of the spare tire location on the trunk floor

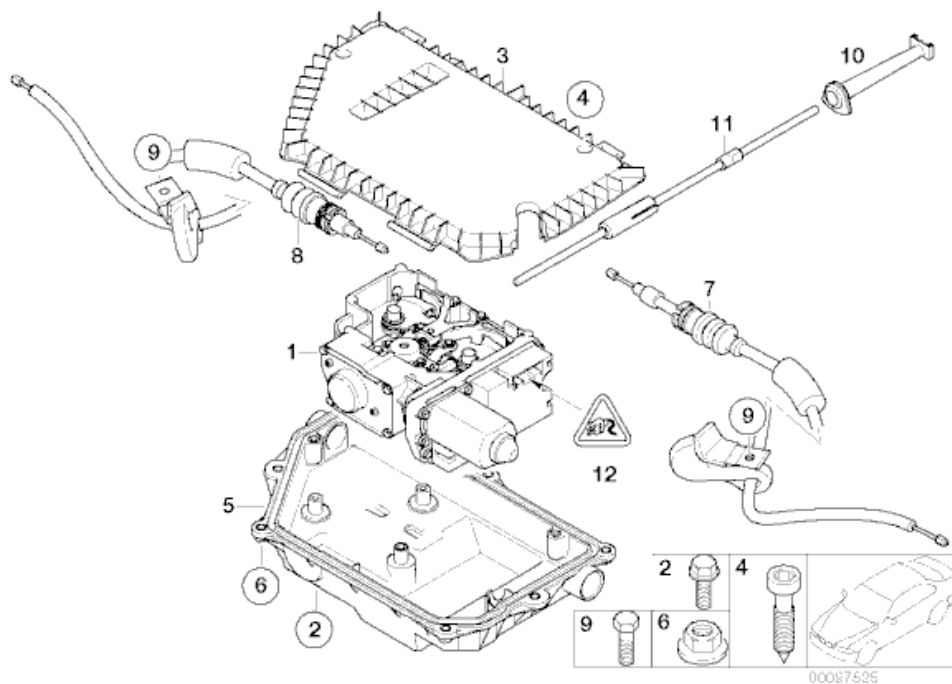

[http://www.realoem.com/bmw/showparts.do?model=GN63&mospid=47785&btr=34\\_1240&hg=34&fg=30](http://www.realoem.com/bmw/showparts.do?model=GN63&mospid=47785&btr=34_1240&hg=34&fg=30)

## **Tools Needed:**

Hydraulic Press

Bench Vise

Drill Press

1/8" Drill Bit for Metal (for roll pin)

#20 and #25 Torx

7/8" deep socket

Hammer

Compatible BMW diagnostic computer

Remove plastic cover over parking brake actuator. This allows access to the internal retainer for the metal shaft screw to be removed later.

Remove the four side cover screws using a T25 Torx driver.



Once you remove the four screws you can remove the cover. Inside you will see the damaged gears.



Next remove the T20 Torx screw for the retainer that secures the metal shaft.



And then remove the retainer.



Next unscrew the main shaft that the large gear was on. Also remove the smaller gear, this just pulls straight out.



Use the supplied altered nut (1 inch ID.), a narrow press tool or  $\frac{1}{4}$ " extension and a hydraulic press to press apart the main shaft.



You want to center the narrow press tool or  $\frac{1}{4}$ " extension on the center of the shaft.



Take the old tapered metal parts, using a hammer gently tap into the new plastic gear until fully seated.



Using a 7/8" socket and a bench vise press the metal gear out of the plastic gear.



Using a hammer gently tap the metal gear into the new plastic gear until fully seated.



Reinstall the smaller gear just by sliding into place.



Now press together the parts on the larger shaft in the reverse order removed. Make sure to fully seat each part.

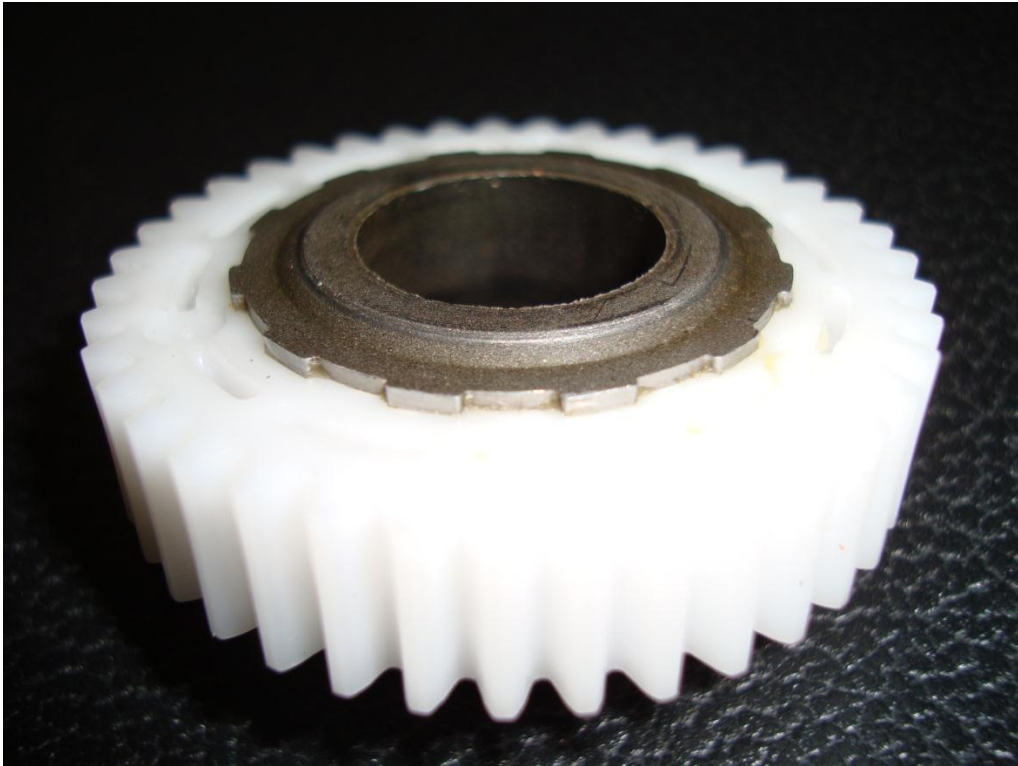

This is what the gear should look like when fully seated!  
Notice the 1/8" lip of metal sticking out.





Before installing the new gear apply a small amount of grease to the bushing/bearing section. Press on the upper collar, being careful not to install too tightly as to not bind the movement.



Place the assembly into a bench vise and using a drill press with a 1/8" drill bit. Drill a hole through the upper collar and into the center shaft. Be sure to drill in at least 1/2" (12.71mm) so that the split pin does not bottom out before being installed flush. **It is also recommended to place a small spot weld on the center shaft to outer collar.**

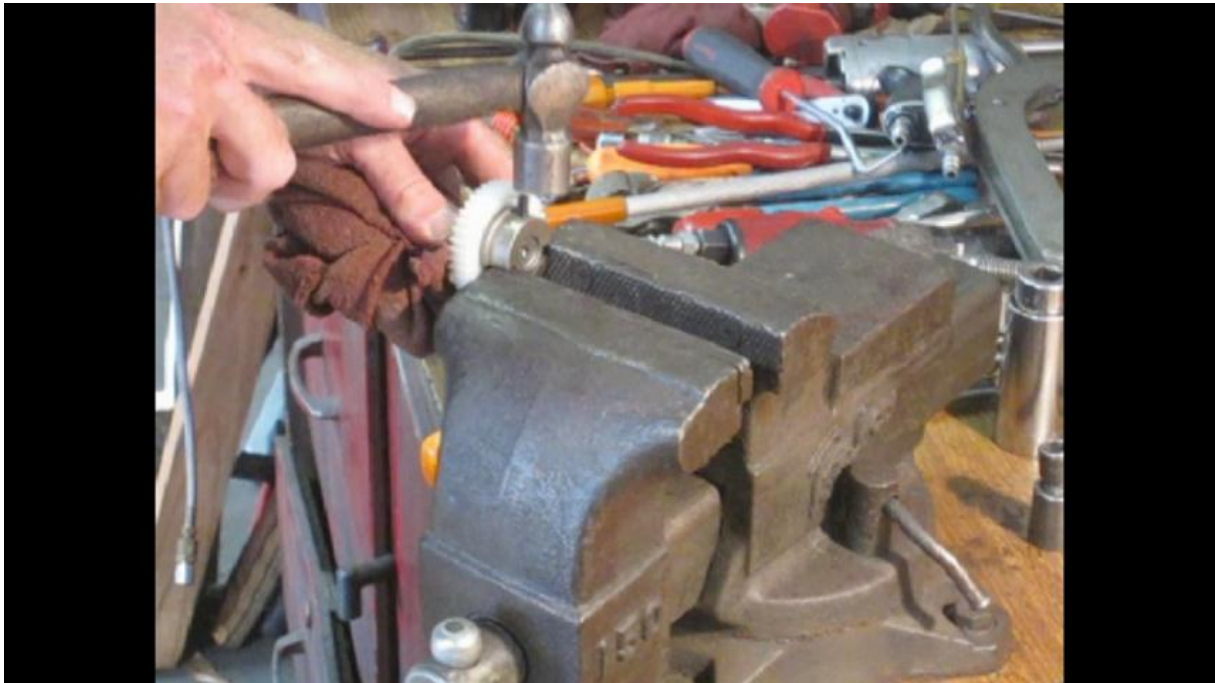

Reinstall the main shaft with the new gear: pull up on the internal mechanism and screw the shaft in until it stops, gently press straight down until the gears mesh together and are fully installed.



Reinstall the retainer for the shaft with T20 Torx screw.

Reinstall unit in vehicle is removed. Reinstall covers.

## Final Steps

~Clear codes for parking brake system using an appropriate scan tool

~Ignition on and press parking brake button 4 times after clearing codes

\*Failure to clear codes will render the parking brake system inoperative

**We have recently been informed that you will also need a compatible BMW diagnostic computer to reactivate the parking brake system.**

**BMW Description of the functionality of the Electromechanical Parking Brake.**

Starting off on a slope, in stop-and-go traffic or whenever the engine is turned off: the Electromechanical Parking Brake ensures your BMW stays comfortably and reliably at a standstill whenever required.

Working together with Dynamic Stability Control (DSC), the Electromechanical Parking Brake controls all braking processes whenever the vehicle is not moving. If the engine is running, it operates hydraulically via the DSC brake system. If the engine is switched off, electromechanical brake cables support the function of the conventional handbrake. The Electromechanical Parking Brake can be activated by pressing a button on the instrument panel or, depending on your BMW model, on the centre console. It also offers an autostop and hillhold function.

Autostop automatically activates the parking brake whenever the vehicle comes to a halt; it disengages the moment you touch the accelerator. In vehicles with automatic transmission, it is no longer necessary to keep the brake pedal applied to prevent vehicle creep when stopping in gear, such as in stop-and-go traffic or at traffic lights. This makes city driving significantly more comfortable.

Hillhold automatically applies the parking brake whenever your BMW stops on a slope, preventing unwanted rolling, and disengages it when you start off again.

[http://www.bmw.com/com/en/insights/technology/technology\\_guide/articles/electromechanical\\_parking\\_brake.html](http://www.bmw.com/com/en/insights/technology/technology_guide/articles/electromechanical_parking_brake.html)