



www.OdometerGears.com

Saturn Odometer Gear Repair

First three sections show how to remove cluster from the dash. The last section (page 13-) shows how to disassemble the cluster and replace the odometer gears.

These pages, and the FAQ's, are strictly for suggested ways to fix your equipment. They are not intended to be absolute. The user/buyer of the FAQ's and new gears are solely responsible for any damage or accuracy that may occur to their property. If you are not sure how to take something a part, ask on the many car boards that are available. The user has to keep his eyes open and use common sense.

Please read the first few steps carefully as these are our most common questions we receive after a client has performed a repair and the odometer still does not work.

The reason the original gear or gears have failed is that they are made of urethane and lubricated with petroleum grease. This combination breaks down the urethane into a waxy substance which flakes and breaks away. This will also leave a waxy film and deposits on the shafts, gears, housing and peg on the pods.

* Work smart, meaning have a clean area to work and the proper tools to perform the repair.

General tools that will be needed depending on the vehicle are small standard screwdriver, small Phillips screwdriver, assortment of torx drivers, diagonal cutters (dikes), 1/4" socket set are just a few of the items that may be needed.

* No grease is needed with the new gears. Our gears are made using Celcon® which has graphite mixed into the material and does not require any additional lubricant.

* Make sure that you have blown the speedometer and odometer assembly clean with high pressure compressed air. **Even if you think that you have found all of the broken pieces you still need to perform this step.**

* Wipe the area around the gears, any shaft or shafts that the gears may ride on, the motor shaft and the peg on the pod that the small gear spins on clean, using a clean cloth and rubbing alcohol. Any residue left over from the old gears can allow the new gears to stick and not allow the odometer to work.

* On units that use a gear and pod combination: install the gears into the housing first and then install the motor assembly. Before installing the screws that secure the motor and circuit board use a small standard screw driver and rock the tenths digit of the odometer up and down. This will help to seat the gears into place and allow the motor assembly to seat fully.

Part 1 – Removing the Instrument Cluster to get to the Odometer Gears.

Tools Needed:

Small 7MM Socket Wrench

Large Screwdriver

Small Screwdriver

Removing the Instrument Panel or Cluster: The removal of the Instrument Cluster is a very delicate job. You should take care and patience when performing this task. If you work through this fast you may run the risk of breaking something and then have another replacement on your hands. The replacement procedure is very detailed, so make sure you follow each step thoroughly. Good luck. Pictures attached will detail the steps as you go along. Some of these details are taken directly from the Saturn Service Manual Body/Collision Repair Section Page 476. If you have not done this before; plan on at least 2 hours total to get Part 1 of this procedure complete. Your time may vary based on experience with working on your car; and how your car parts behave to being removed. The procedure in the following photos was performed on a 1991 Saturn SC. The interior of your car may be similar or different; these photos are to show you the procedure in fixing your vehicle. These photos are for educational purpose.

1991 – 1994 S-Series Instrument Cluster Removal:

http://www.differentracing.com/tech_articles/91-94cluster.html

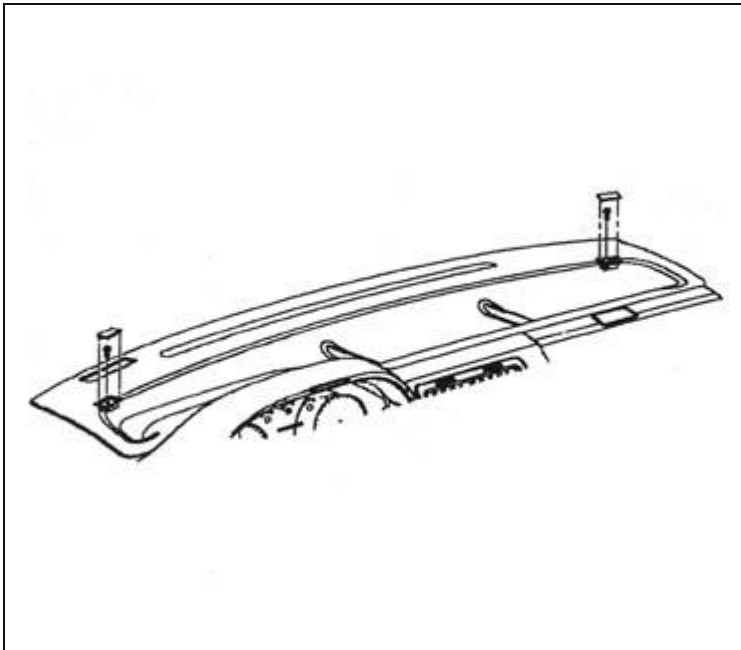

- Disconnect negative battery cable.
- Remove upper trim panel screw caps by carefully prying with a small flat head screwdriver.
- Remove upper trim panel screws.

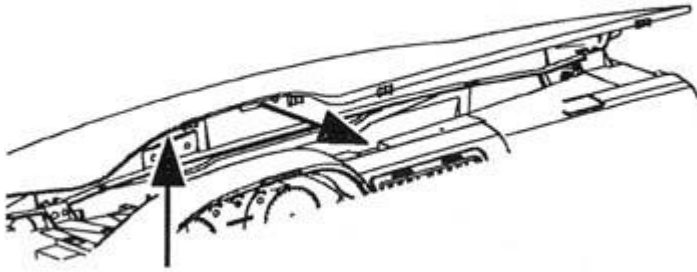

- Lift upper trim panel to disengage clips at rear edge.
- Pull panel rearward out of clips at the bottom of windshield.
- Remove upper trim panel

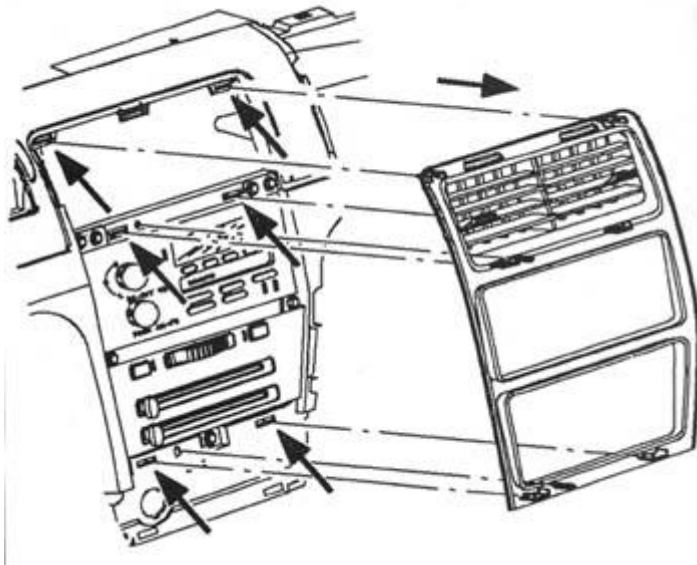

- Carefully remove center air outlet / trim panel by pulling outward at clip locations. (1991 vehicle center trim panel shown in illustration).

Notice: Start at bottom and work up to top clips. Do not use instruments that may damage trim panel.

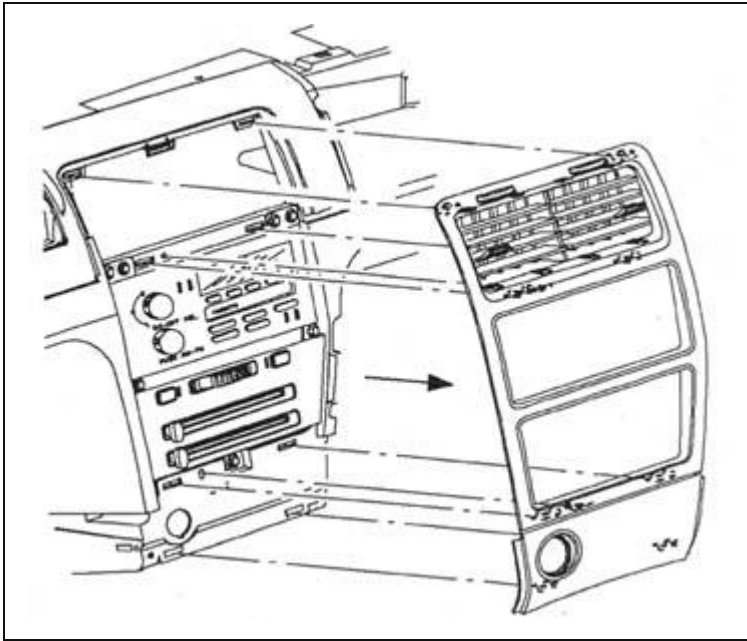

- 1993-1994 vehicles, remove and disconnect traction control / fog lamp connector if equipped. (1992 - 1994 vehicle center trim panel shown in illustration).

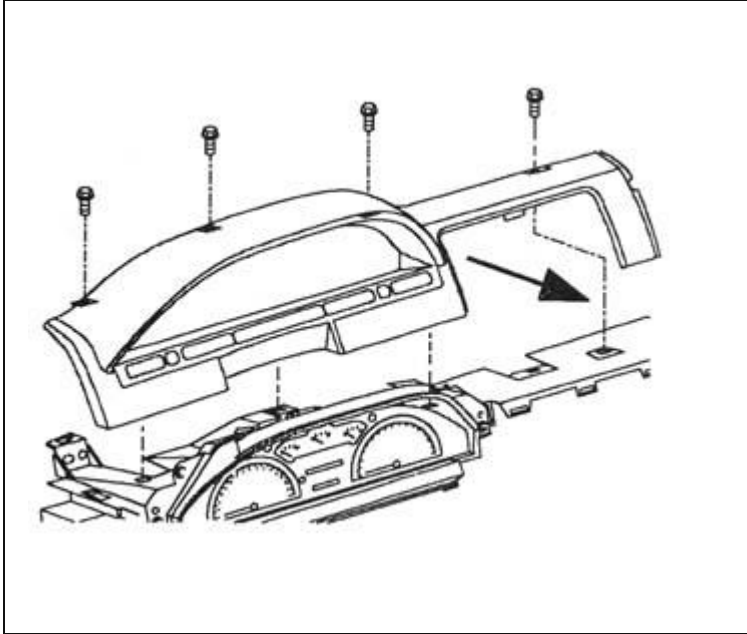

- Open glove box
- Remove screws and pull cluster trim panel rearward to disengage retainers.

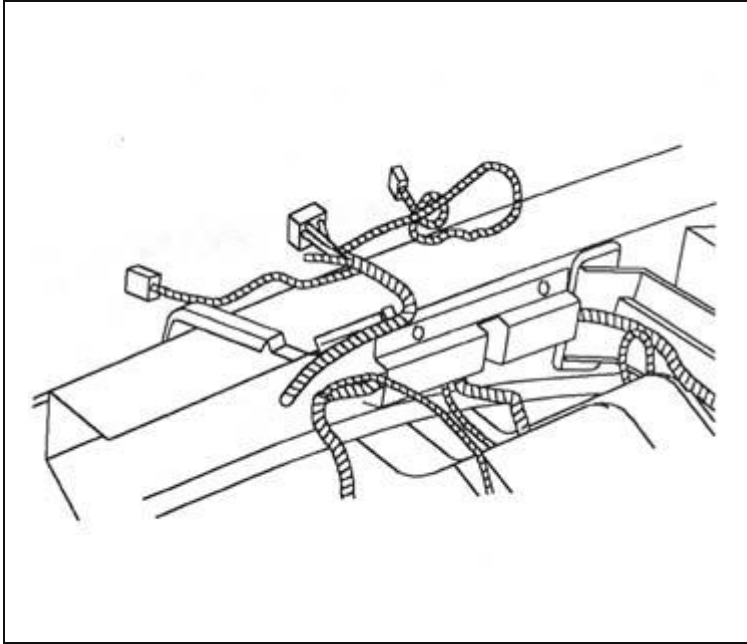

- Remove connector position assurance (CPA) devices and disconnect electrical connectors from instrument panel lighting rheostat and rear window defogger switches.
- Remove cluster trim panel.

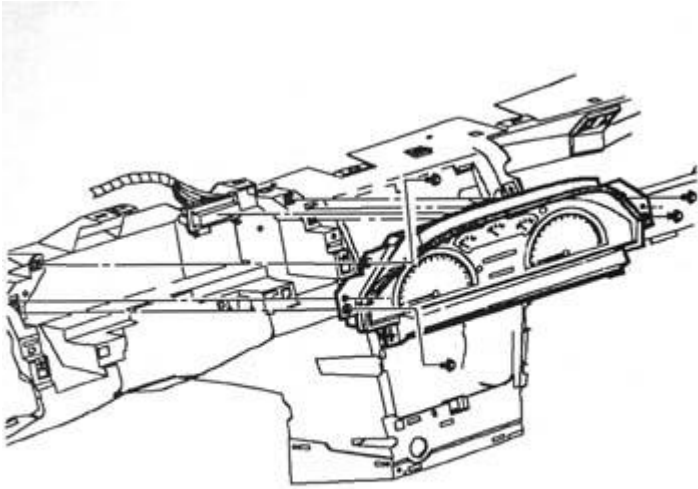

- Remove screws and pull instrument cluster out enough to disconnect electrical connection.
- Disconnect electrical connectors by depressing retainer legs and remove instrument cluster.

Reinstall in reverse order.

1995 – 1999 S-Series Instrument Cluster Removal:

http://www.differentracing.com/tech_articles/95-99cluster.html

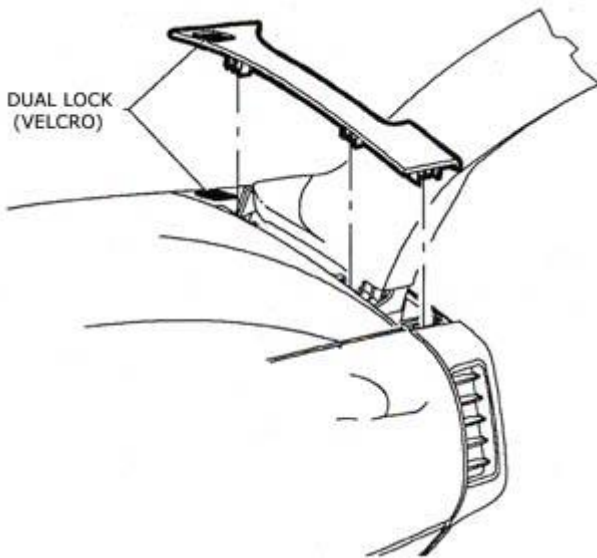

- Remove upper trim panel extension by carefully lifting up at clip locations, starting at the rear above end cap (1995 models only).

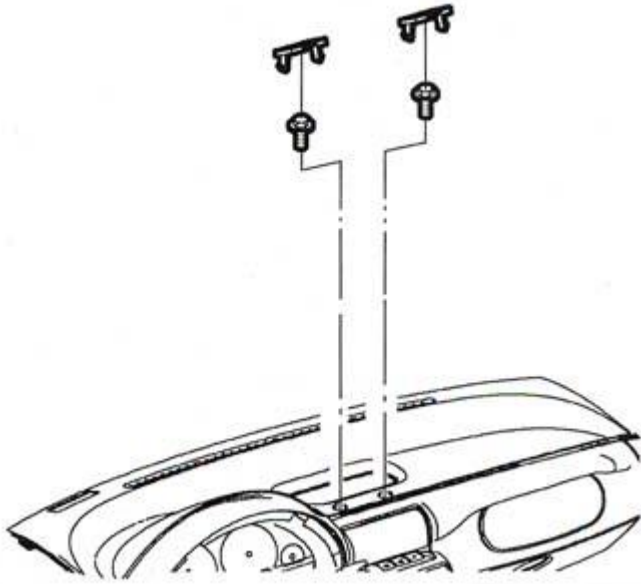

- Remove upper trim panel screw caps by carefully prying with a small flat head screwdriver.
- Remove upper trim panel screws.

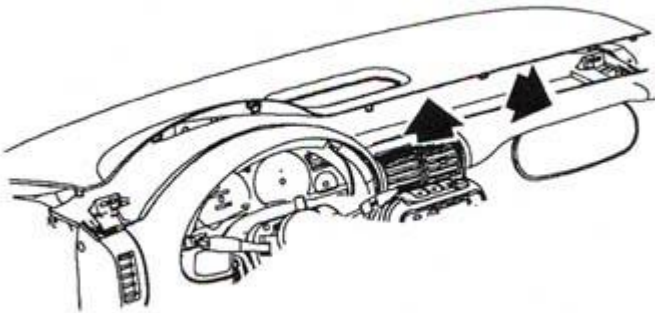

- Lift upper trim panel at clip locations on rear edge to disengage clips.
- Pull panel rearward out of clips at bottom of windshield.

NOTE: Be careful not to damage VIN plate when removing upper trim panel.

- Remove upper trim panel.

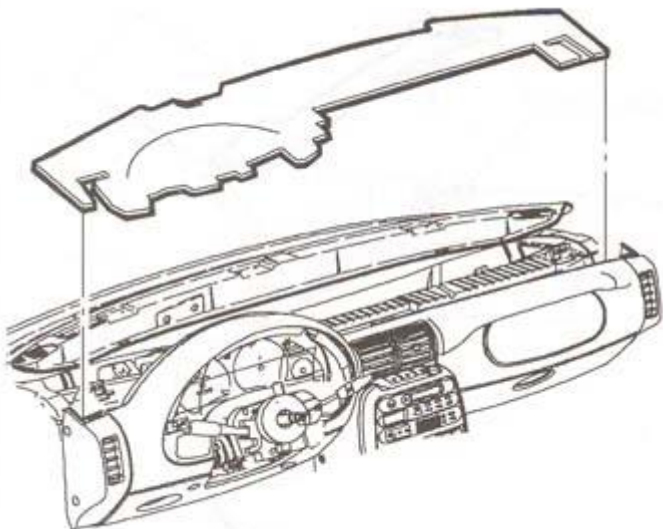

- Remove upper trim panel insulator.

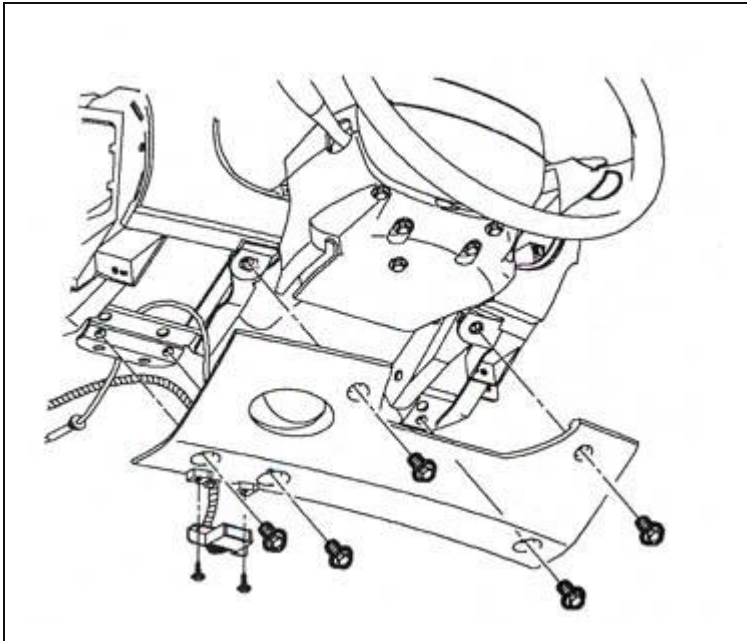

- Remove screws from DLC connector and steering filler panel.

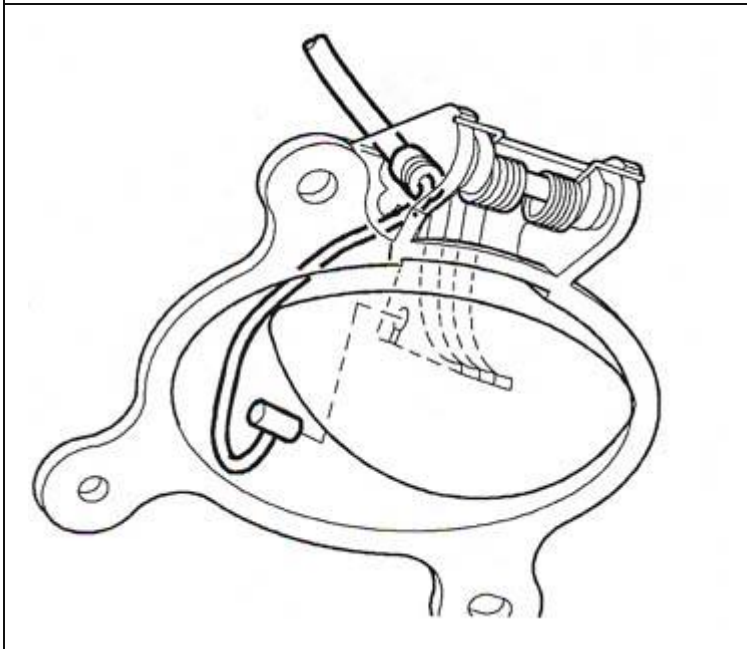

- Remove hood release cable from lever.
- Remove steering column filler panel.

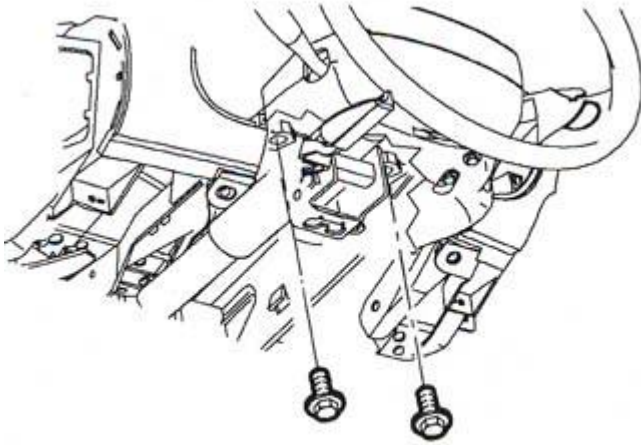

- Disconnect ignition switch electrical connector at right steering column bolt,
- Remove steering column bolts and lower column onto front seat cushion.

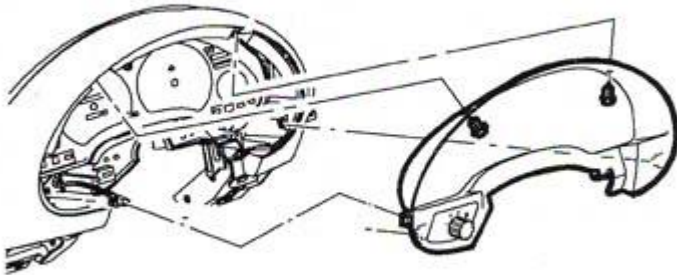

- Remove fasteners and pull instrument cluster trim bezel rearward at clip locations.
- Disconnect electrical connector from instrument panel dimmer switch.

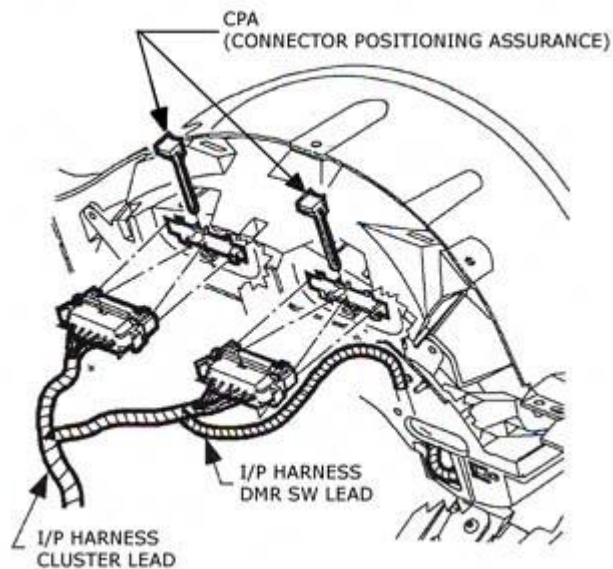

- Remove CPA's and disconnect electrical connectors from instrument cluster by squeezing tabs on each side of connector.

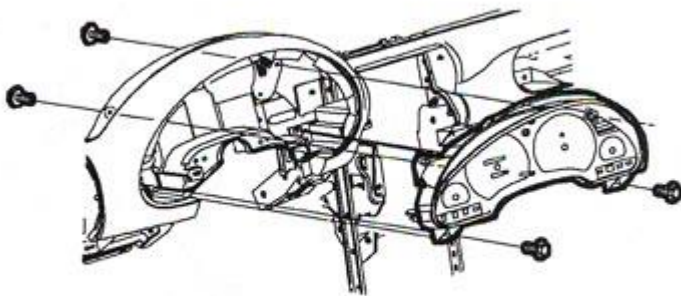

- Remove front and rear instrument cluster screws.
- Remove instrument cluster.

Reinstall in reverse order.

2000 – 2002 S-Series Instrument Cluster Removal:

http://www.differentracing.com/tech_articles/00-02cluster.html

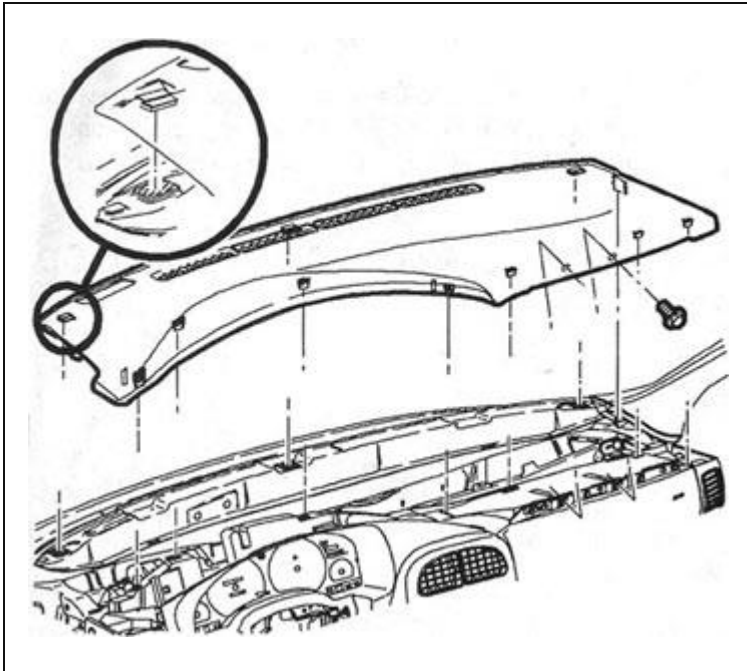

Remove instrument panel upper trim.

- Remove screws located under upper trim panel on passenger side of vehicle.
- Disengage clips at locations by grasping edges of upper trim panel and lifting up.
- Disengage hook-and-loop fastener attachment at rear of instrument panel upper trim by reaching under panel and lifting straight up.
- Raise instrument panel upper trim panel enough to clear the VIN plate

NOTE: Be careful not to damage VIN plate when removing upper trim panel.

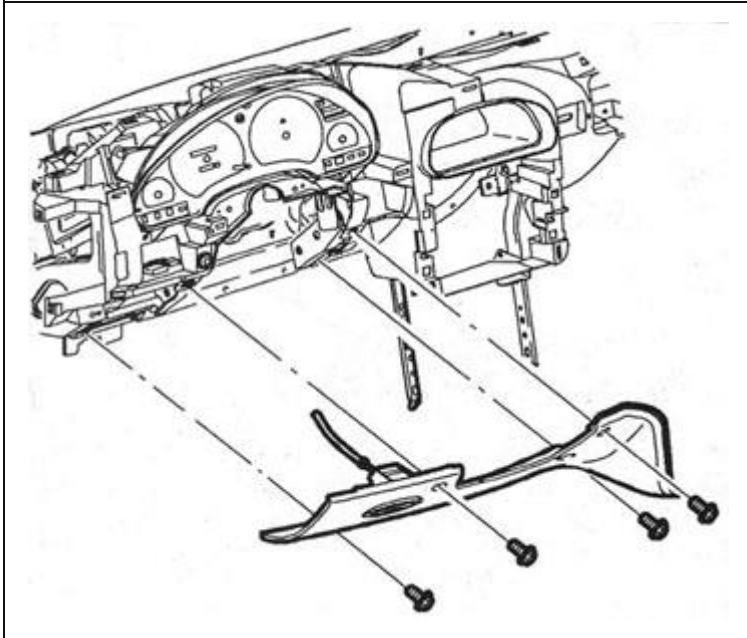

- Remove steering column filler panel

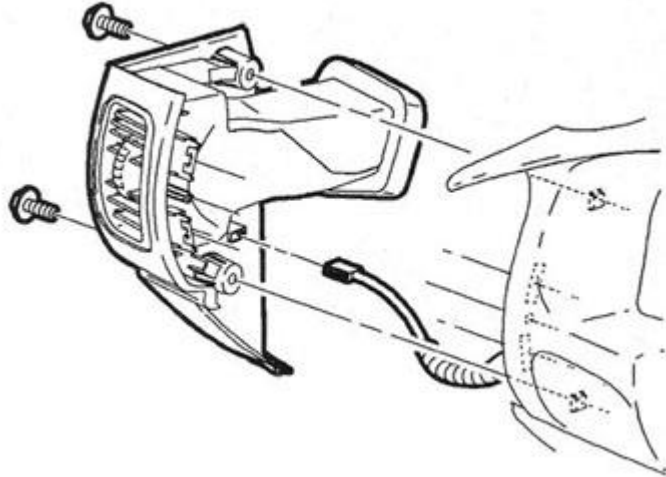

NOTE: Do not remove weather stripping. Adhesion will be lost if removed

Remove left end cap assembly

- Remove screws
- Carefully disengage clips at I/P retainer assembly locations. Use of a blunt tool will aid in disengaging clips.

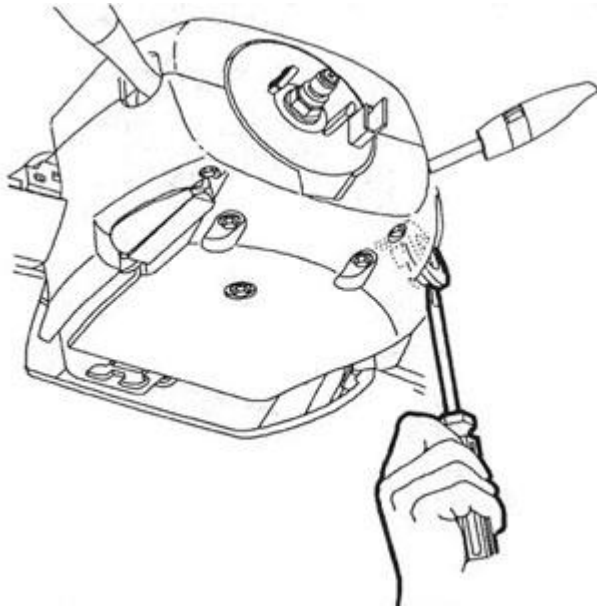

- Gently pry edges of ignition lock bezel with a blunt tool and separate from shroud.

Some have found it possible to skip this step.

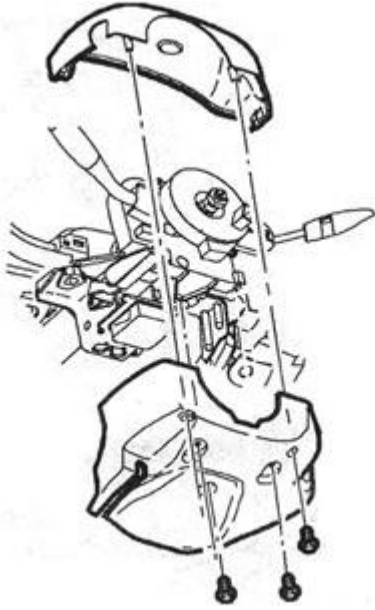

- Remove screws and lower steering column shroud.
- Lower steering column by pushing down on steering column adjusting handle.
- Lift and remove upper shroud from steering column.

Some have found it possible to skip this step.

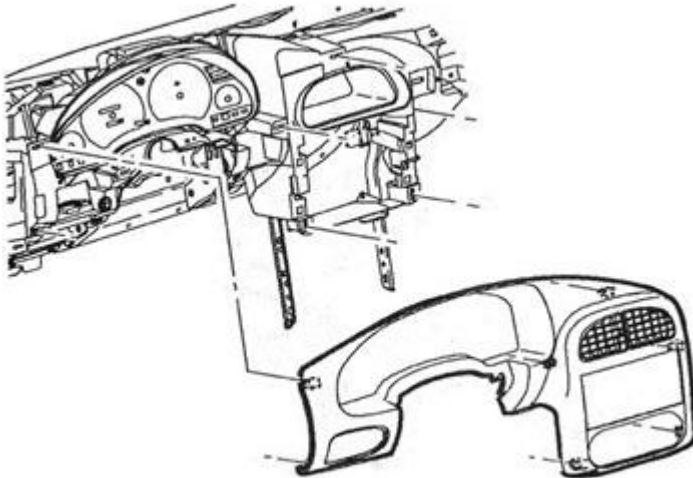

Important: It is not necessary to disconnect the I/P switch (dimmer / traction / fog) connector.

Move I/P bezel out of the way

- Disengage clips from retainer assembly by grasping edges of bezel near clip location and pulling outward
- Move I/P bezel to gain access to radio fasteners.

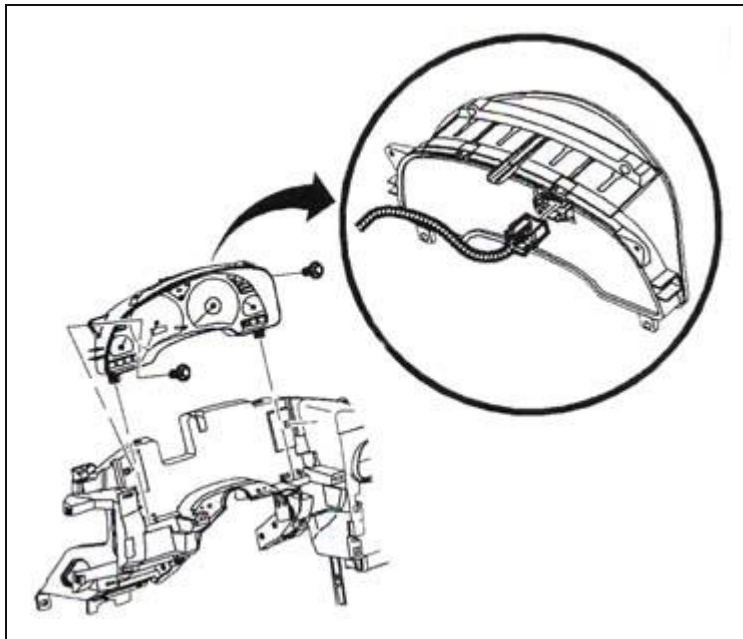

Remove instrument panel cluster

- Remove fasteners
- Disconnect electrical connector from I/P cluster by squeezing tabs on each side of connector.

Install in reverse order.

Part 2- How to get inside your Instrument Cluster

Tools you will need:

Flathead Screwdriver

Putty Knife

Phillips Head Screwdriver

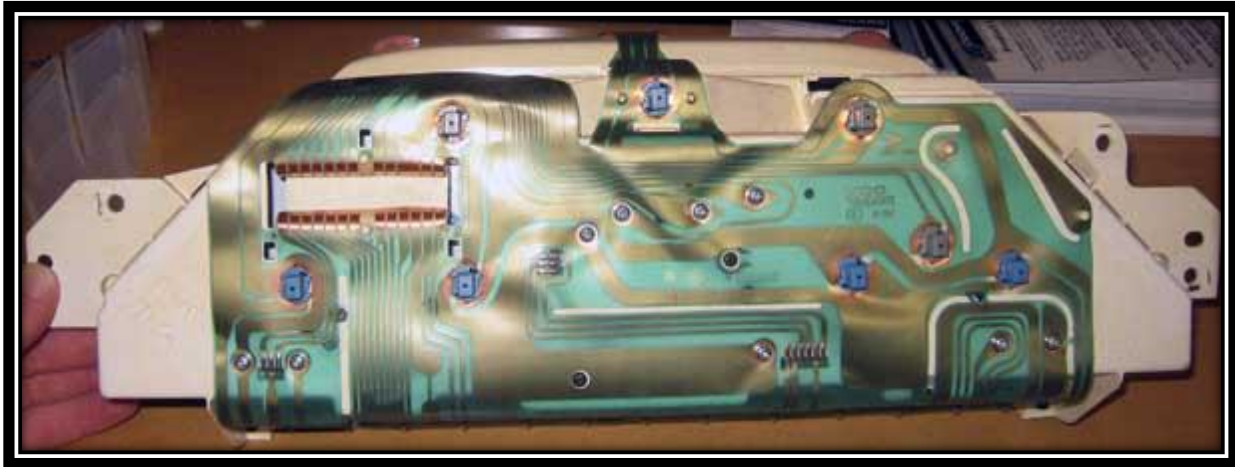

1. Label all Appropriate Light/Lamp Locations.
2. Remove each lamp carefully (these bulbs will be reused). Twist/Turn and then Pull. Turn Counterclockwise 1/8 turn and then pull out of socket.
3. Inspect for Burnt out lamps, set lamps aside on appropriate home created lamp location sheet. Lamp sizes are as follows: Blue=73, Gray=74 you CAN find these at Advance Auto Parts, but they are pricey (\$2.50 a package!)
4. Begin removing SILVER Screws from back electrical circuit board film. There will be 8-10 Silver Screws.

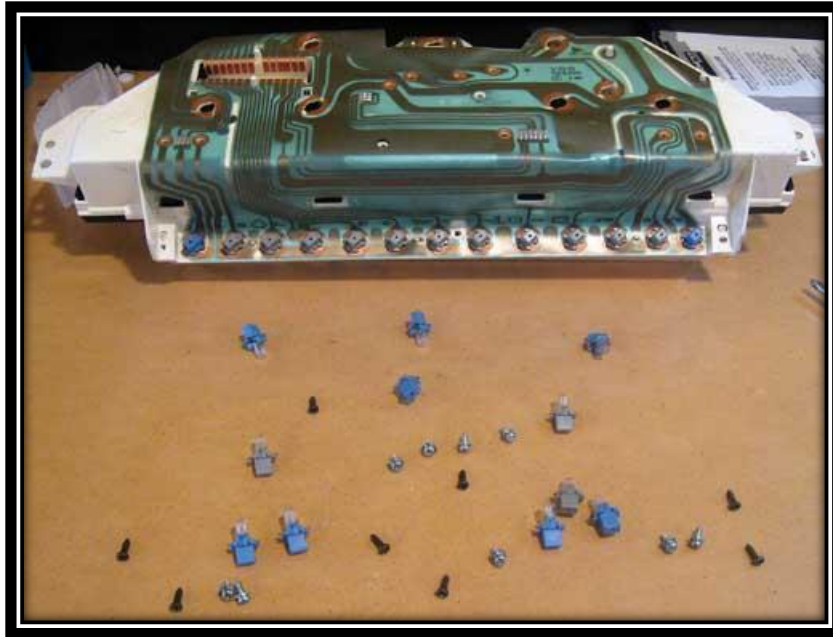

5. Remove Circuit Board Film. BE CAREFUL! To remove, slowly pull up from guide posts and pry up with putty knife. Slowly move top portion of Circuit Film until it slides out. Continue working with putty Knife.

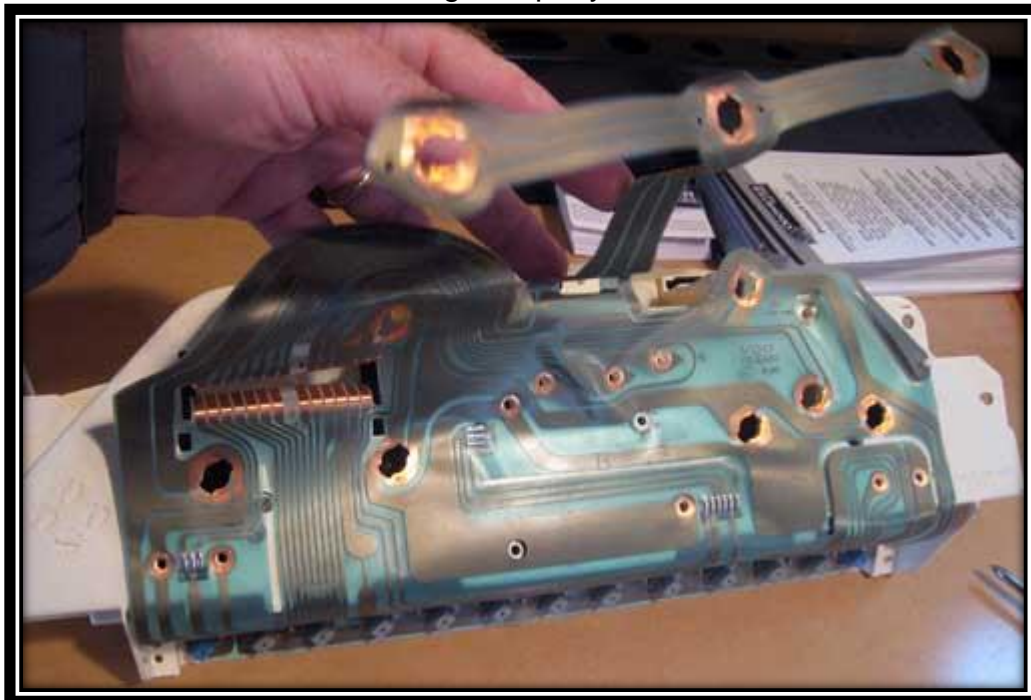

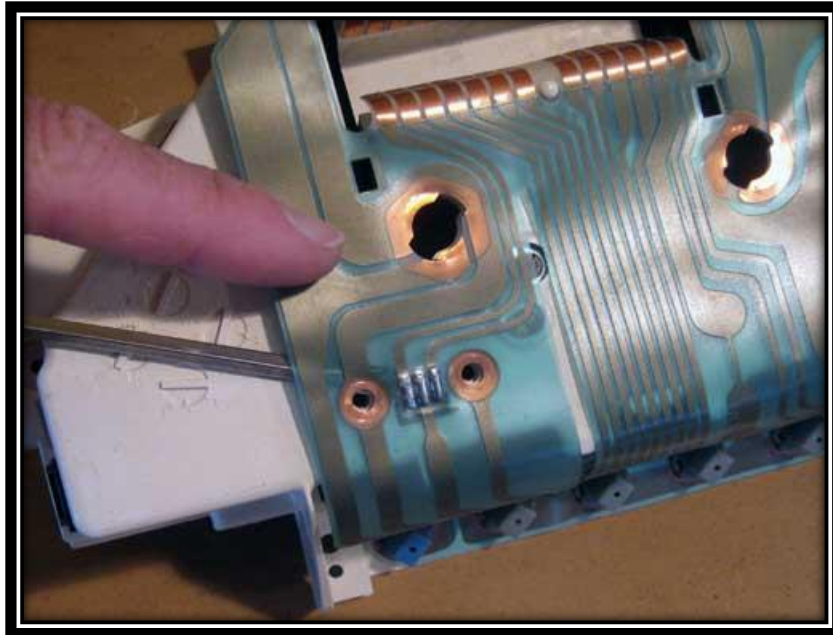

6. Remove BLACK screws from the back and around the perimeter of the instrument panel cluster. There will be 8-10 black screws along the perimeter. The Warning Light Display can then be removed.

7. Work putty Knife or a medium size flat blade screwdriver to Electrical Contacts for Speedo/Tach/Odometer to completely remove Electronic Circuit Film. Each of the three silver electrical connections for the Speedo/Tach/Odometer has pins that connect into a black receptacle under the film. The pins must be pried out of the connectors (perpendicular to the film, male/female connector) to separate them from the respective instrument and remove the film.

8. Using a finger, push tabs for instrument cluster face plate down and forward to remove.

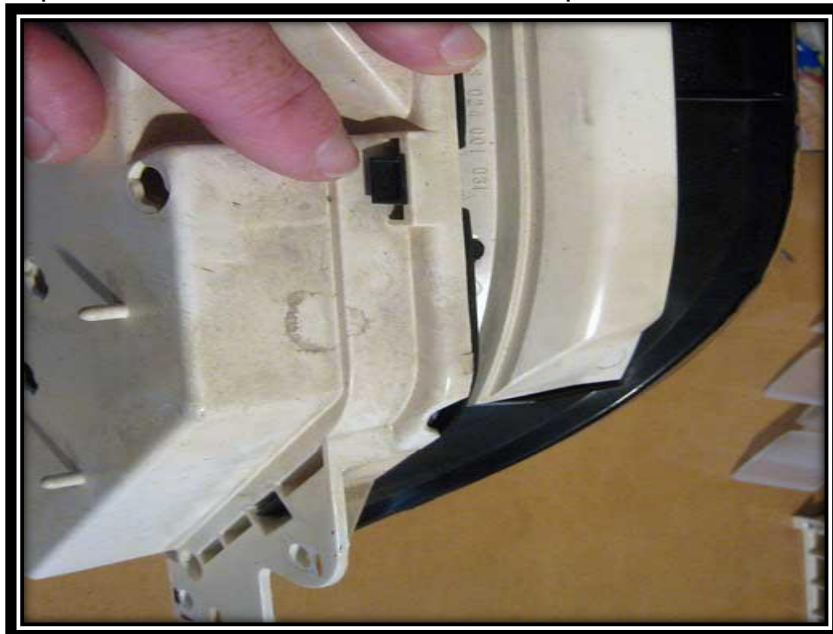



9. Using a standard screwdriver-Begin to Pry up on Left Corner of Faceplate and PULL but be gentle. There will be a lot of loud crunching, but do not be alarmed, it will take time, but it will come off.

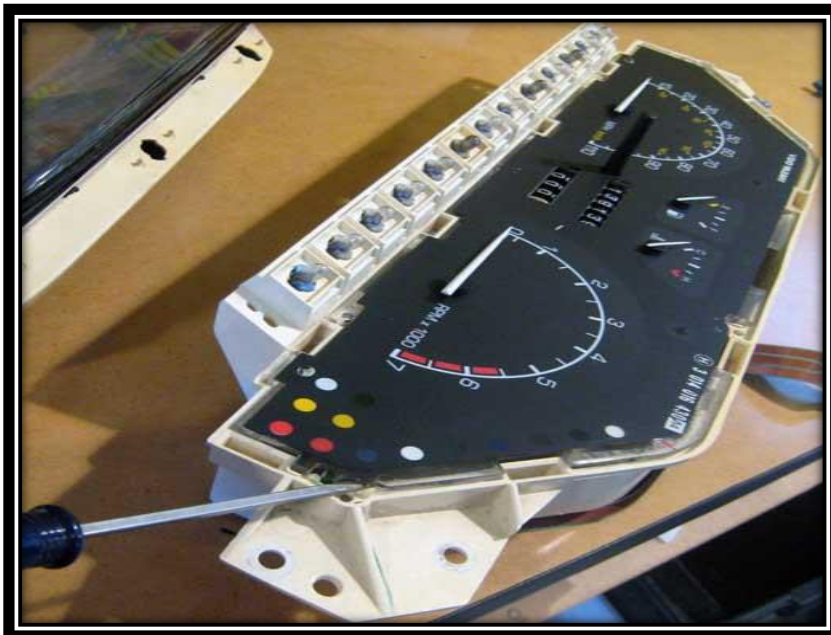

10. Once you have removed the faceplate remove the screws that hold the Odometer Gear Cluster in place.

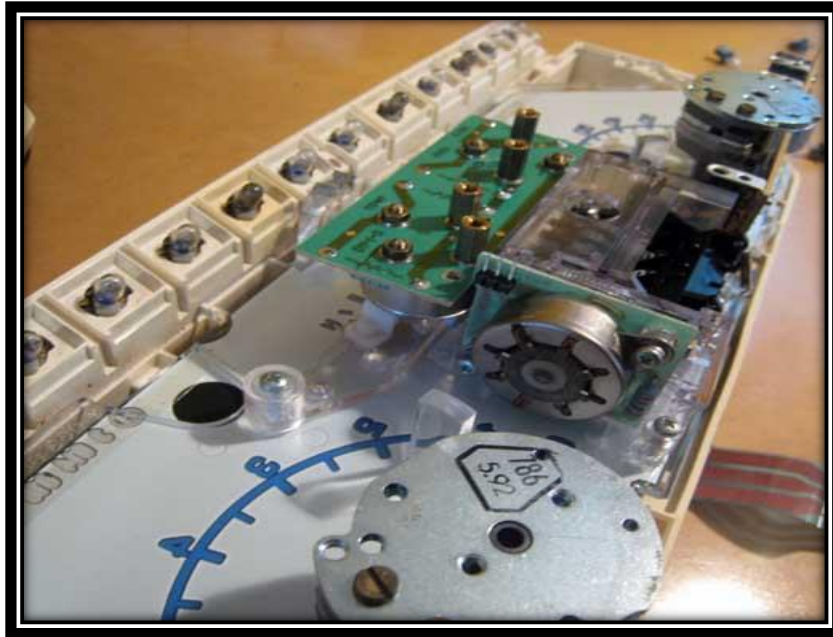

11. Remove Odometer Gear Cluster

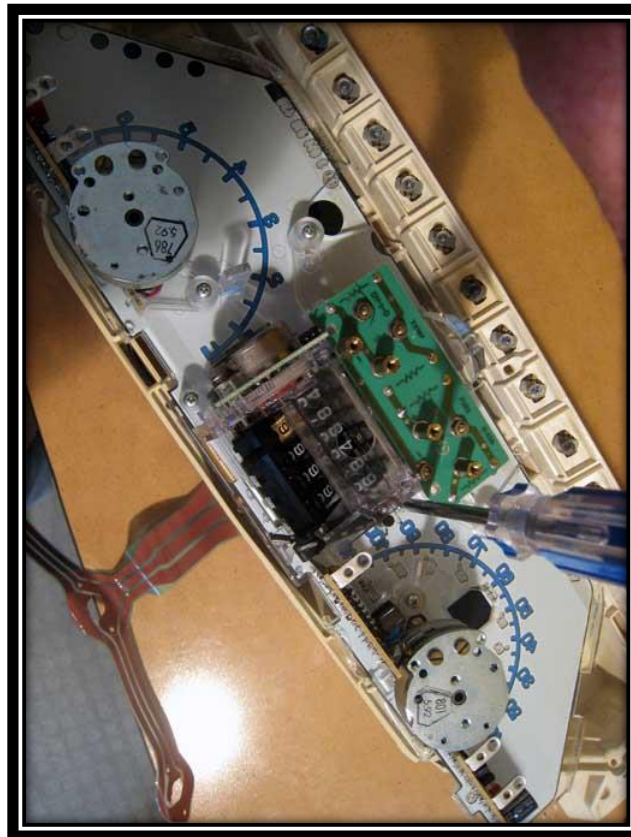

12. Remove 2 Screws to remove Odometer Gear Motor (Note: electrical connector faces towards the front so the electrical wires can attach.)

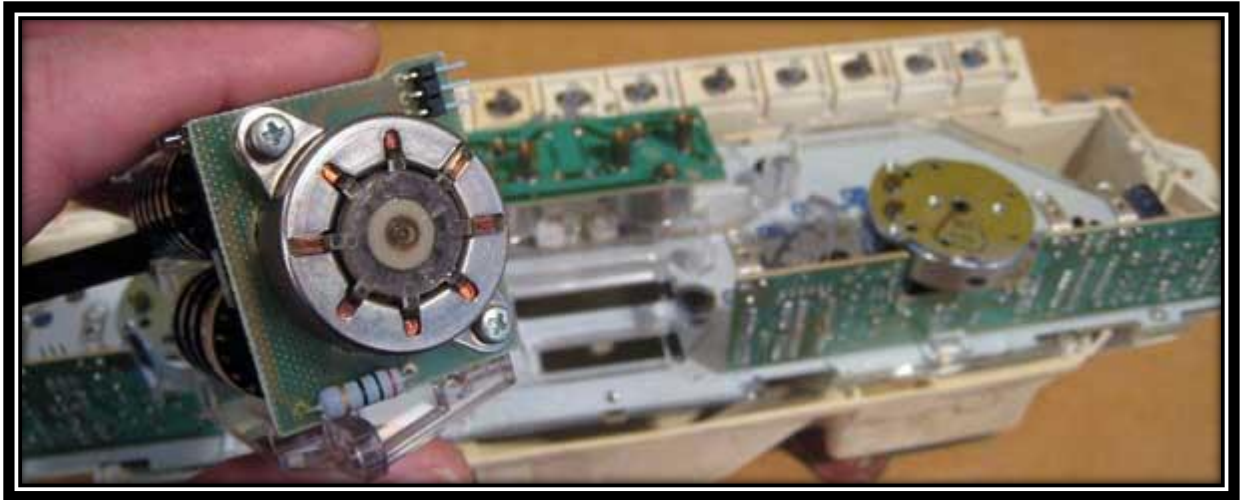

13. Remove Odometer Gears to reveal Broken 25 tooth gear and 15 tooth large pod.

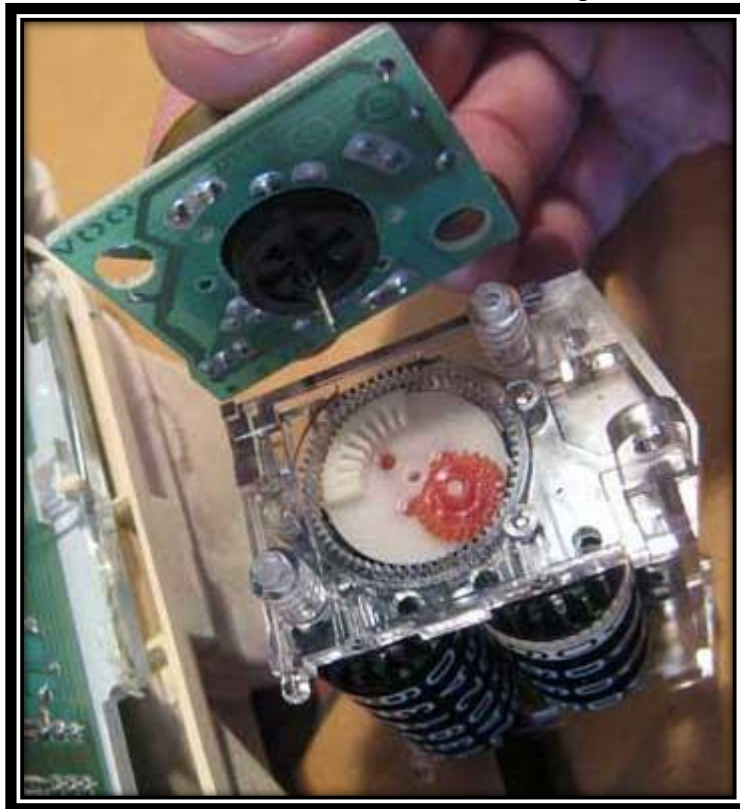

The white plastic in the above photo is the pod.

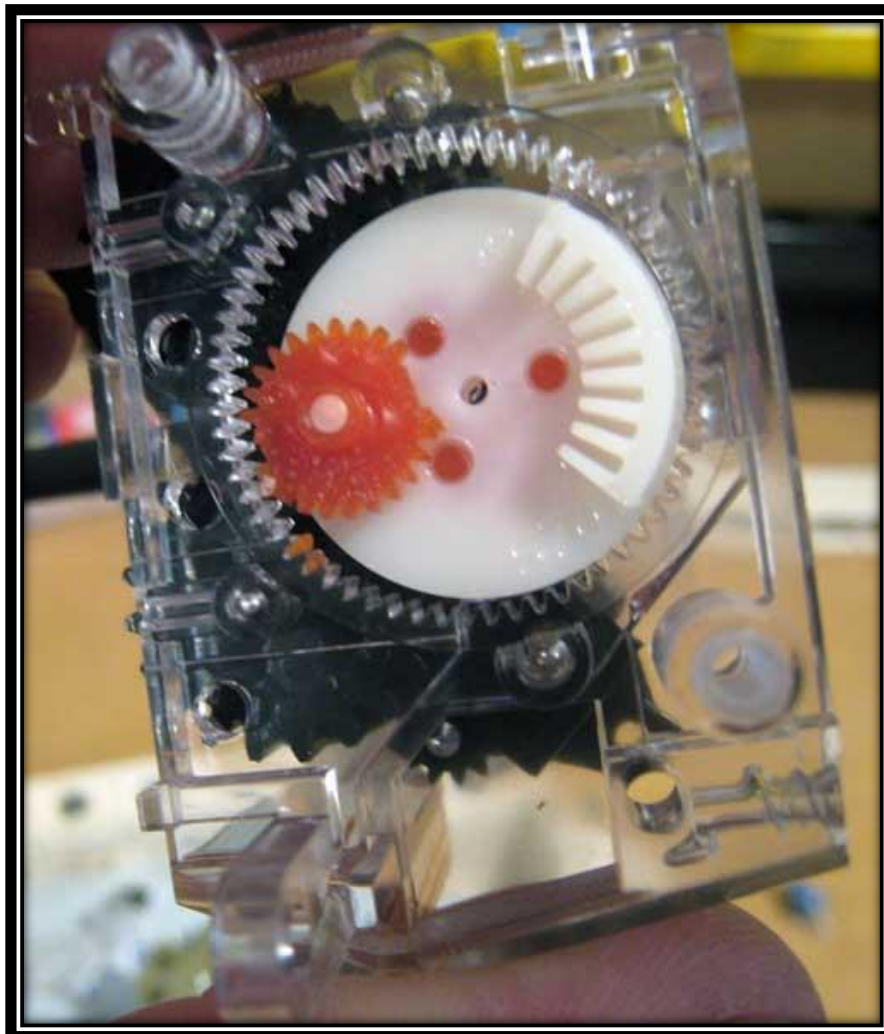
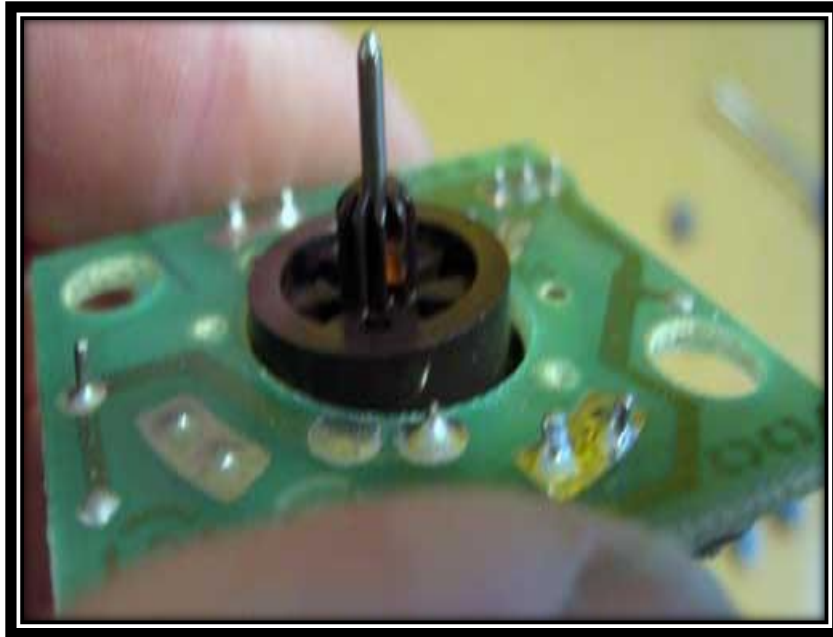

14. Use shop compressed air, thoroughly blow out unit. Inspect for any small traces left by the old gear on the motor shaft and gear housing and remove. Even a tiny piece left over will cause the odometer to not work after reinstalled, so look closely.
15. Wipe old grease from plastic housing and motor shaft. The old grease can also cause the new gears to not spin freely and not allow the odometer to work properly.

16. Install the new gears and then reinstall the motor (no grease is need as our gears are self lubricating)

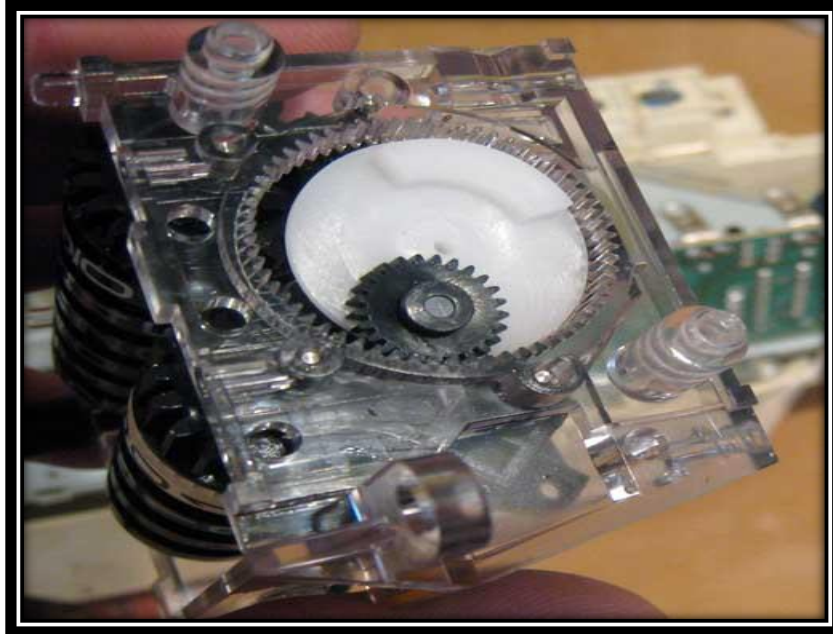

17. Wiggle the one digit of the odometer to make sure that the gears are meshing properly.

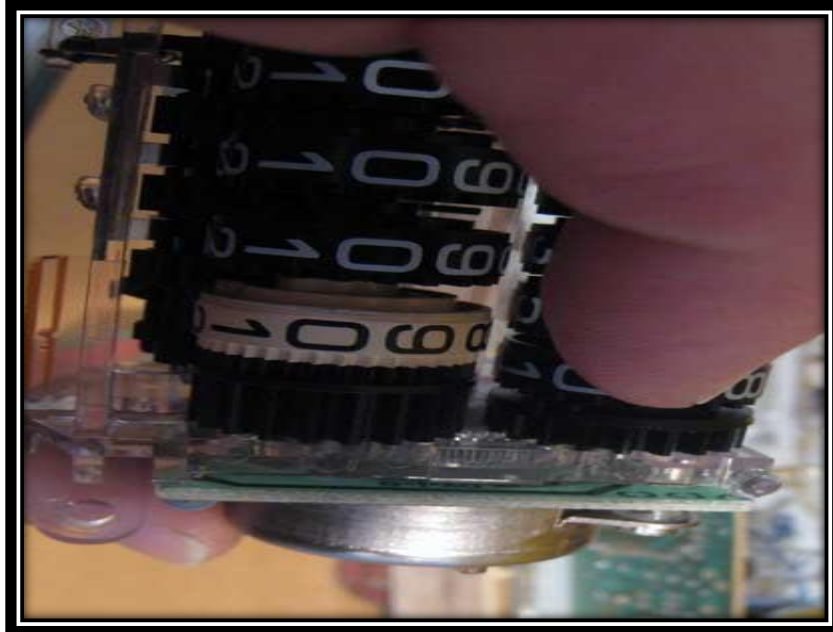

18. Install is reverse of removal.



www.OdometerGears.com